

HORNE®

Product datasheet: T306A

HORNE SHOWER PANEL WITH PUSH BUTTON TIMED FLOW CONTROL & SWIVEL SHOWER HEAD Includes integral Type 3 Approved HORNE 15 thermostatic mixing valve pre-plumbed within a white epoxy-polyester powder-coated aluminium panel with push button timed flow control and easy clean swivel shower head in chromium plated finish.



FEATURES & BENEFITS

- Durable, anodised and powder-coated (RAL 9010) panel and robust fittings ensure long lifespan
- Pressure and performance tested pre-plumbed assembly
- Integral healthcare approved Horne 15 thermostatic mixing valve (pre-set)
- Fixed swivel shower head
- Timed flow control for water and energy conservation (approx. duration 45 seconds)
- Integral 8 L/min flow regulator for water and energy conservation
- Highly suitable for retrofit applications
- Fast and easy installation
- Integral low level isolating service valves for ease of maintenance
- Optional Accessory:
- pipe cover in same profile as panel

The HORNE 15 is a UK Water Reg 4 and Type 3 Approved thermostatic mixing valve.



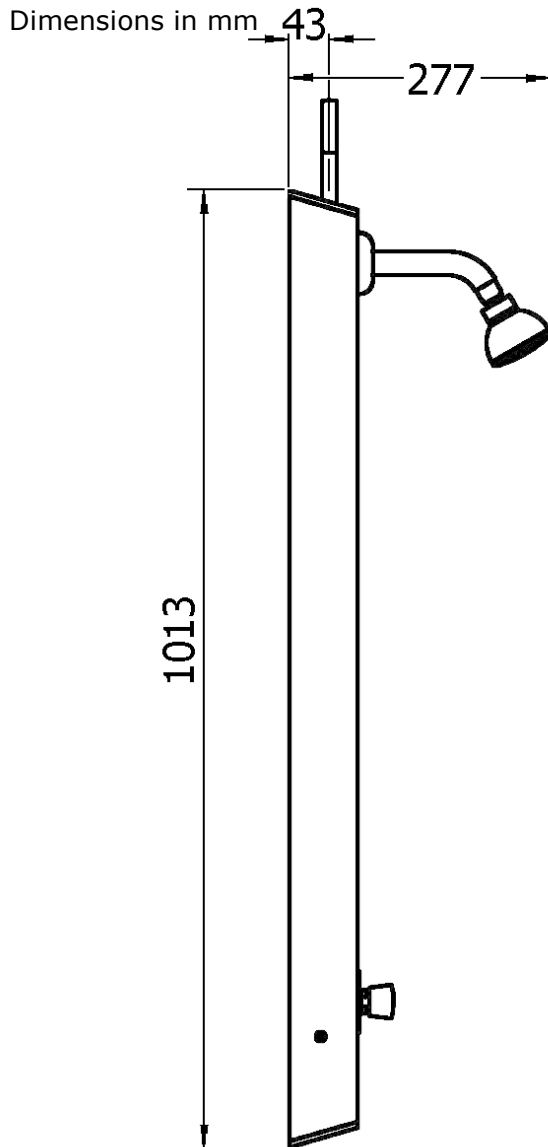

The T306A shower panel is pre-plumbed with an integral Type 3 approved thermostatic mixing valve, which features:

- Low level isolating servicing valves
- Integral fine mesh strainers provide essential protection to the internal mechanism of the valve & ancillary fittings
- Angle pattern inlets enable easy access to the strainers
- Integral check valves prevent cross migration of water supplies
- Flushing facility to allow water supplies to be flushed clean during commissioning

Operating Conditions (Type 3 TMV):

- Pre-set mixed water temperature, 41°C at the shower head
- Range of hot water supply temperature: 55 - 65°C
- Maximum static pressure: 10 bar
- Minimum differential between hot water temp. and mixed water temp.: 5°C
- Range of maintained water supply pressures: 0.5 - 5 bar

Unequal pressures are usually acceptable if gravity-pressure supplies one of the inlets: minimum 0.5 Bar. When both supplies are pumped, pressures should be nominally balanced.

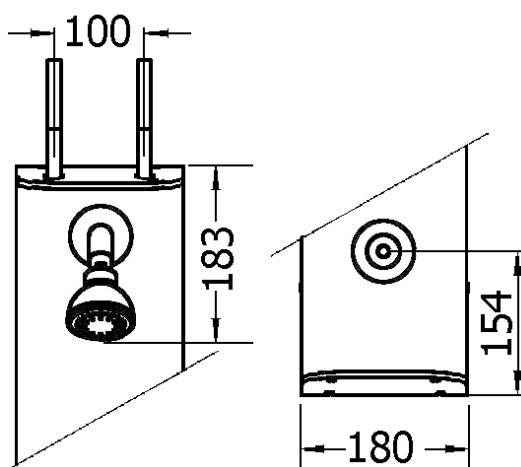

HORNE ENGINEERING LTD, PO BOX 7, Rankine Street, Johnstone, PA5 8BD.
Tel: +44 (0)1505 321455 Fax: +44 (0)1505 336287
Email: sales@horne.co.uk web: www.horne.co.uk



Certificate No. FM 1224