



Horne Engineering Ltd  
PO Box 7, Rankine Street  
Johnstone, PA5 8BD  
Tel: 01505 321 455  
Fax: 01505 336 287  
Email: [Technical@horne.co.uk](mailto:Technical@horne.co.uk)  
Web: [www.horne.co.uk](http://www.horne.co.uk)

## **HORNE THERMOSTATIC SHOWER PANEL – T113/T206 Ranges**

FOR SURFACE MOUNTING WITH TIMED FLOW CONTROL

### **INSTALLATION, OPERATION & MAINTENANCE INSTRUCTIONS**

#### **General Requirements and Information**

##### **Supply Water Pressure Requirements**

The minimum water pressure required to achieve a spray at the shower head is a dynamic head of 5m (7psi, 0.5 Bar). Note that the dynamic head is the pressure measured with the water running.

Where one supply is tank fed and the other pressurised, (e.g. cold mains and tank fed hot, or pressurised hot and tank fed cold), a pressure reducing valve on the higher pressure side is not required provided the lower of the two pressures is equivalent to at least a 5m (7psi, 0.5 Bar) dynamic head at the shower head.

The maximum recommended dynamic supply pressure is 6 Bar (90psi, 60m head) for hot, and 10 Bar (150psi, 100m head) for the cold.

##### **Supply Water Temperature Requirements**

Max. Hot water temperature 85°C

Min. Hot water temperature 55°C

Max. Cold water temperature 20°C

##### **Temperature Adjustment Range**

The mixed water temperature can be adjusted by the user from cool through to a top limit (which can be preset during installation – factory set to approx 41°C – with full anti-scald protection throughout the range).

##### **Water and Energy Conservation**

The TSV1 range shower panels are fitted with flow regulators at the shower outlet to reduce the flow rate and conserve water and energy. The drawings at the end of this document provide information for accessing the flow regulators for removal or replacement.

##### **General**

Every T113/T206 variant is supplied with a single check valve and integral large area strainer on each inlet. The Shower Panel terminates in 15mm copper pipes for hot and cold supplies. The hot pipe is on the left, cold on the right, when viewed from the user's perspective.

Note that a T113B and T206B model is also available. A "B" suffix indicates that the shower panel is equipped with braided stainless steel hoses with SOFT-PEX liner at the inlets instead of copper pipes. These permit recessed water entry from behind the panel, rather than above. The final page of the installation section of this manual provides installation instructions for B variants.

Also note that ligature resistant models (T113ALR and T113BLR) are also available, which feature a ligature resistant shroud around the push-button timed flow control. Models with a BS 8300 compliant lever control on the user temperature adjustment (T113A1L, T113B1L, T206A1L and T206B1L) are also available.

The Timed Flow Control Cartridge supplied with all variants has an adjustable duration, and is factory set to 55 seconds (maximum duration). This is adjusted using the supplied Hex Key through the hole in the front of the Pushbutton. See Fig. 9 on Page 7 for details.

## PANEL INSTALLATION INSTRUCTIONS

### General

The surface mounted shower panel is supplied with a fitting kit containing the necessary fixings to attach it to the wall and hex keys to assist with routine maintenance.

### Installation

Installation of the pre-plumbed enclosure is particularly simple and involves mounting the enclosure on the wall and connecting and flushing the water supply pipes.

#### 1) Position the Pre-Plumbed Enclosure

Identify a suitable position for the pre-plumbed enclosure and mark a line on the wall level with the top of the casing. Mark a point on the wall that is on the required centreline for the valve 35mm below the line of the top of the casing, for the support screw (see Fig. 1).

#### 2) Install the Support Screw

Drill a 7.0mm dia. hole in the wall and insert a wallplug and screw, leaving the head of the screw a few mm from the wall surface.

#### 3) Hang the Enclosure on the Support Screw

Remove the top cover of the pre-plumbed enclosure using the supplied hex key to remove the 2 retaining screws. Hang the pre-plumbed enclosure on the support screw by the larger hole in the middle of the backplate and let this take the weight of the enclosure (see Fig. 2).

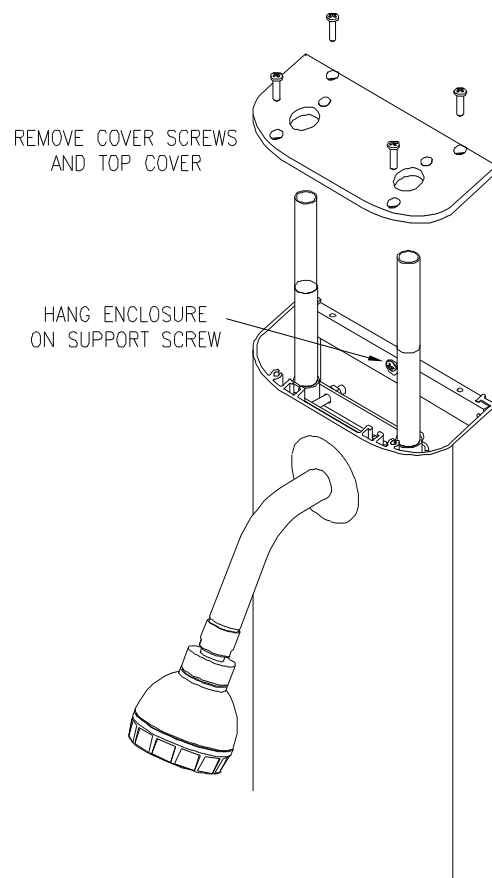
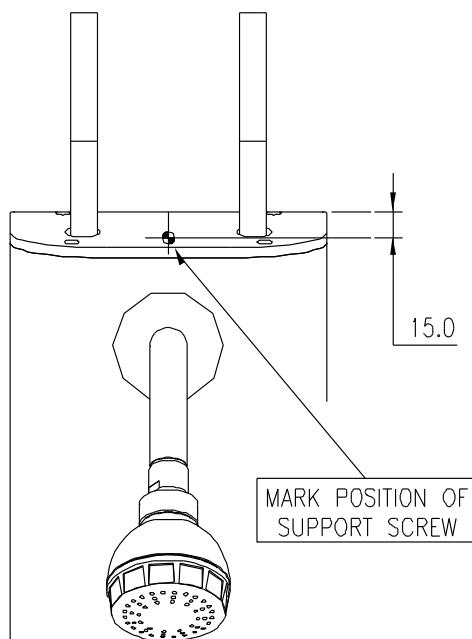

Fig. 1

Fig. 2

#### 4) Mark Out the 4 Support Holes.

Ensure that the enclosure is hanging true and then mark out the holes for the 2 upper support holes. Remove the bottom cover of the pre-plumbed enclosure using the supplied hex key and mark out the 2 lower support holes (see Fig. 3).

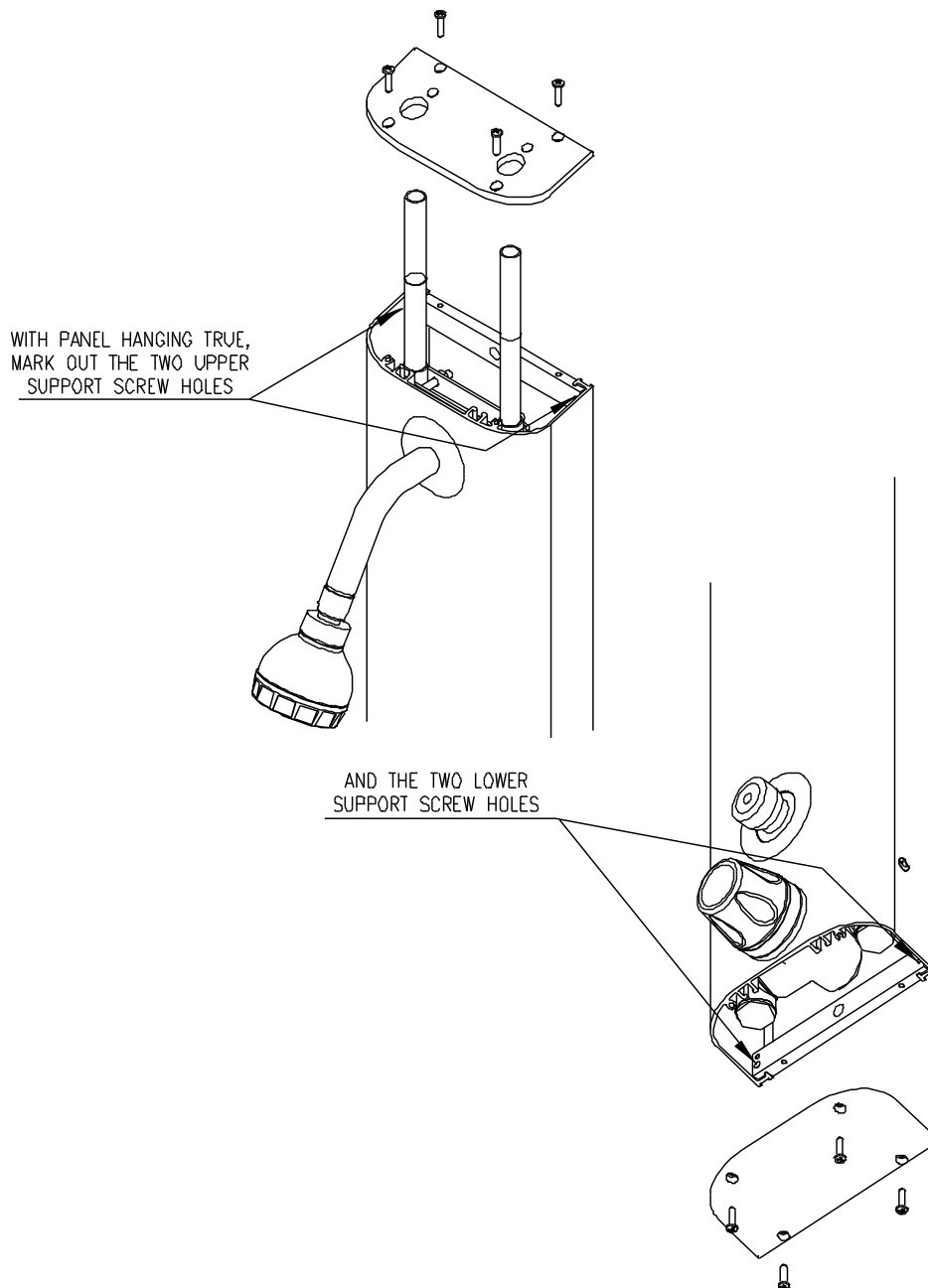

Fig. 3

**5) Drill Support Holes.**

Carefully remove the pre-plumbed enclosure from the temporary support screw and, being careful not to scratch the enclosure or top and bottom covers, lay it down where it will not be damaged. Drill 4 x 7mm dia. support holes and install the wall plugs.

**6) Attach the Pre-Plumbed Enclosure to the Wall**

Carefully re-hang the pre-plumbed enclosure on the temporary screw and then attach it firmly to the wall by the other 4 screws. **Use the stainless steel screws supplied.** A bead of silicon mastic can be used, if required, to cover any gaps behind the panel on uneven walls to prevent the ingress of water. **Do not** Mastic the lower end cap to the wall. See Fig. 4.

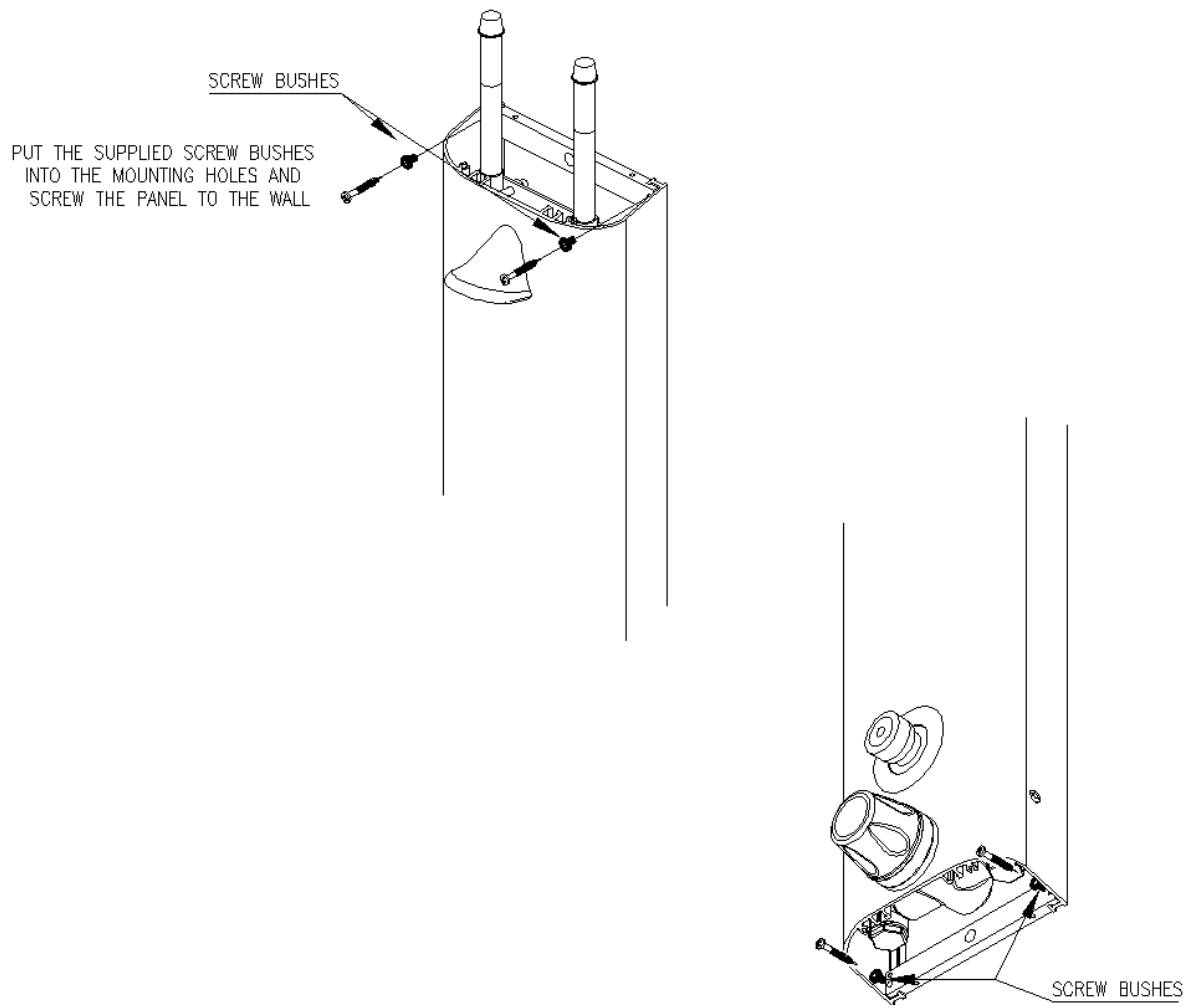

Fig. 4.

### 7) Connect the Supply Pipes

Ensure that the top cover of the pre-plumbed enclosure is replaced prior to connecting up the supply pipes.

Connect the HOT water supply to the LEFT HAND inlet, and COLD water to the RIGHT HAND inlet (see Fig. 5).

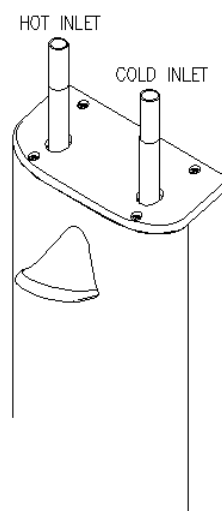

Fig. 5.

**DO NOT OPEN THE WATER SUPPLIES AT THIS STAGE AS THEY HAVE NOT BEEN FLUSHED OUT TO REMOVE DEBRIS IN THE PIPEWORK. SUCH DEBRIS CAN DAMAGE THE VALVE.**

### 8) Flush the Pipework

Flush out the pipework in accordance with Water Bylaws 2000 (Scotland) and BS 6700:1997 England and Wales. The use of a Horne Flushing Kit is strongly recommended, because this connects directly to the water inlets of the mixing valve. Access to the flushing points is gained from underneath the pre-plumbed enclosure through the lower end cap. Isolate the water supplies and also the low level servicing valves located on the side of the panel (see Fig. 6) using the supplied 4mm hex key. Remove the strainer cap with the strainer basket and screw in the flushing adapter. Place the end of the flushing hose in an appropriate drain or container and turn on the supply (at isolation and servicing valve) to flush as required. After flushing, remove the flushing adapter and replace the strainer cap. Repeat for both hot and cold supplies. See Fig. 6 and Fig. 7.

**NOTE THAT IF THERE IS A DANGER OF FREEZING THEN THE PIPES AND VALVE MUST BE DRAINED TO AVOID DAMAGE.**

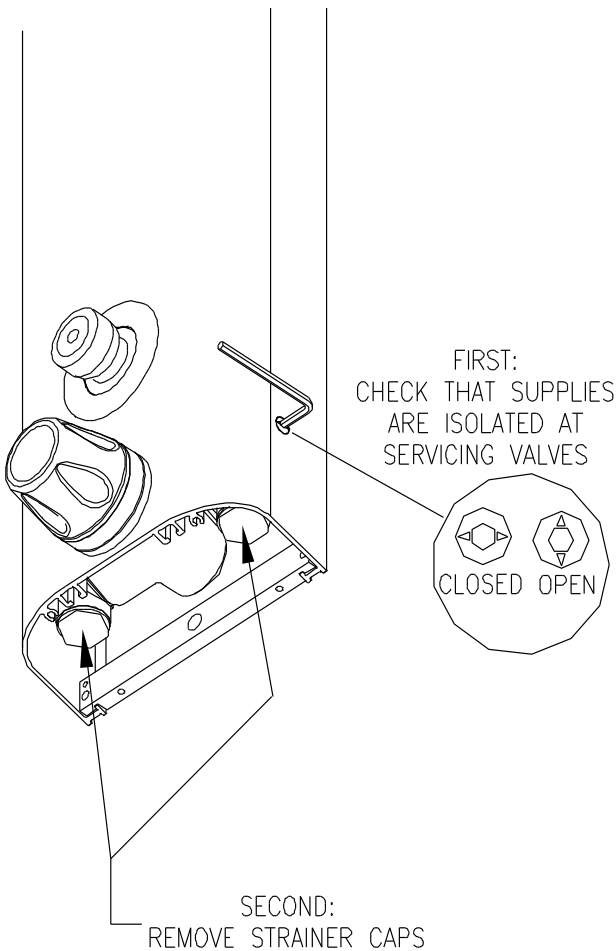

Fig. 6.

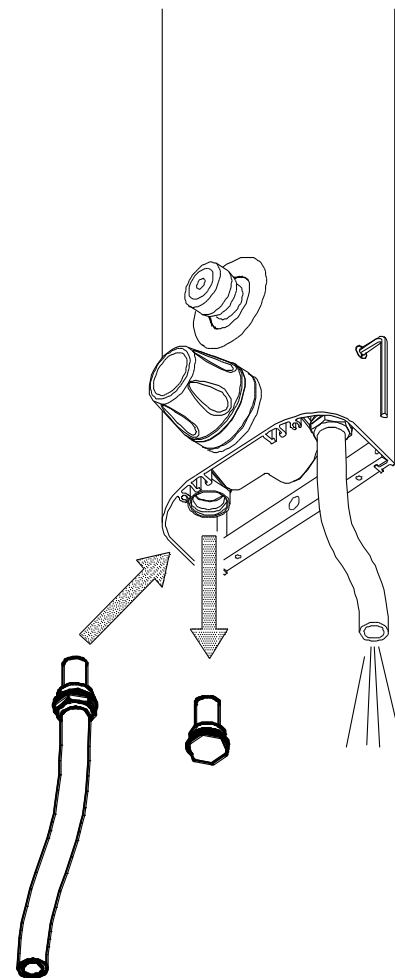

Fig. 7.

### 9) Test for Leaks in Pipework

Open the supplies and check for any leaks at the supply pipe joints. Water should not flow from the sprayhead as the push button timed flow control has not been pressed. Make good any leaks found. The valve is now ready for commissioning.

Note that if any controls, enclosure or shower sprayhead require cleaning then care must be taken not to scratch them in the process. Wash off any surface dust before cleaning with soapy water.

**DO NOT USE ANY ABRASIVE CLEANERS OR SOLVENTS OR THE SURFACES MAY BE DAMAGED.**

## Supplementary Installation Instructions for B Variants.

TSV1 Panel Mounted Shower Valves are available in versions with flexible braided stainless steel inlet hoses rather than top entry copper pipes. These versions have Product References with the suffix B, e.g. T113B.

The main difference, from an installation point of view, is that the water supplies may have to be connected before the pre-plumbed enclosure is attached to the wall.

Accordingly, Point 7 on the attached installation instructions (Connect the supply Pipes) should be performed before Point 6 (Attach the Pre-plumbed Enclosure to the wall) unless alternative access is available to the connections, e.g. via an access panel.

Note that the braided hoses are colour coded with BLUE for the Cold Water Supply and RED for the Hot Water Supply.

Care should be taken to ensure that the weight of the pre-plumbed enclosure is taken by the mounting screws and NOT by the hoses.

### COMMISSIONING

#### **ENSURE THAT THE PIPEWORK HAS BEEN FLUSHED OUT PRIOR TO COMMISSIONING THE COMBINED TSV-TFC SHOWER VALVE (SEE INSTALLATION INSTRUCTIONS).**

Ensure that both hot and cold water supplies are open and at, or near, their design temperatures and pressures, and that they are within the requirements of the valve as outlined on page 1.

Run the shower by pressing the push button timed flow control. The shower will run for approx. 55 seconds before the flow stops and the button needs to be pushed again. Allow the shower to run until the water temperature has stabilised, pressing the push button as required to maintain the flow. Note that the button can be held in, or pressed again before the flow has stopped, to maintain a flow at the outlet.

The T113A is set at the factory to provide a maximum outlet temperature of approx. 41°C but this should be checked on site to ensure that the setting has not been adjusted and that it meets site requirements. To adjust the temperature setting, follow the instructions below:

- a) Adjust the temperature knob fully anticlockwise, to the hot setting, and remove the thermostatic knob cap by gently prising it out using the tip of a pen knife or a sharp blade.
- b) Adjust the temperature using the small slotted screw in the centre of the spindle (see Fig. 8).
- c) Turn the screw anti-clockwise to increase the temperature, or clockwise to reduce it.
- d) After each adjustment, isolate the HOT supply at the ball valve for a few seconds, restore it and check the set temperature.
- e) Operate the shower a few times to ensure the set temperature is correct.
- f) Record the commissioning details on the attached maintenance sheet to permit the in- service performance of the valve to be assessed.

Finally, check the thermal shut-off facility of the valve by performing a thermal shut-off test. Shut off the cold supply at the servicing valve. The flow from the shower should immediately stop or reduce to a trickle, in which case the mixed water temperature should be less than 3°C above the set temperature. In either case, there is no scalding risk. If the temperature rises more than 3°C above the set temperature then it is likely that there is contamination in the mixing valve that is preventing it from shutting off the hot supply. Refer to the maintenance section or phone the factory for advice.

#### **NB Ensure that the Flow Control push button remains pressed during the thermal shut-off test.**

The Timed Flow Control Cartridge supplied with all variants has an adjustable duration, and is factory set to 55 seconds (maximum duration). This is adjusted using the supplied Hex Key through the hole in the front of the Pushbutton. See Fig. 9.

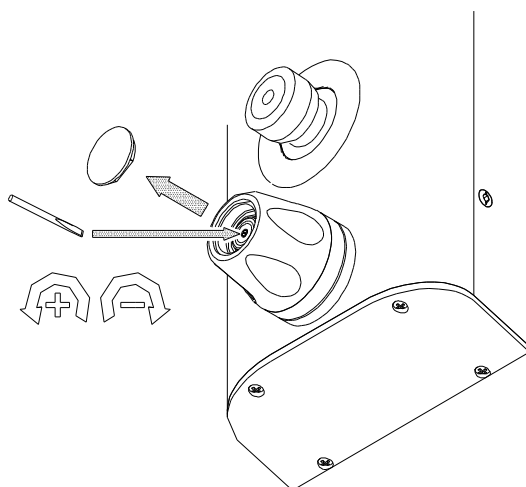

Fig 8

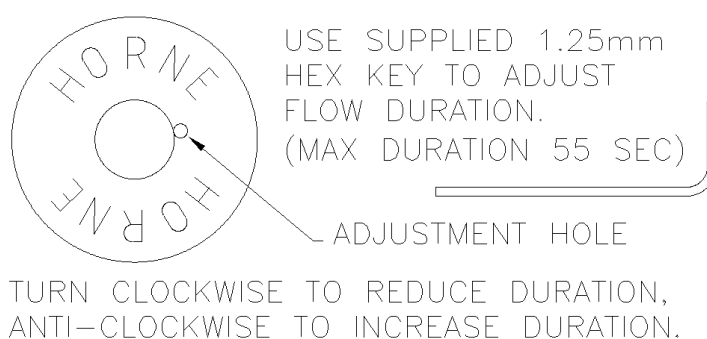

Fig. 9

### MAINTENANCE

Maintenance of the T113/T206 shower valve is essential to ensure that the product continues to perform to specification after installation and continues to afford scald prevention.

Record all maintenance carried out on the attached commissioning and maintenance record.

When cleaning the external faceplates and knobs, never use cleaners containing abrasives or solvents as they may damage the chrome plating. Use only a soft cloth and soap.

The frequency of routine maintenance of the T113/T206 internals (i.e. cleaning, descaling etc) depends largely on the condition of the water supplies, and local knowledge will dictate suitable intervals. In addition to this the following precautions should be observed:

Initially check the strainer baskets for debris every three months and clean if required. This period can be increased, if appropriate, once the general condition and cleanliness of the water is established.

Perform a thermal shut-off test every three months, and check the maximum temperature setting.

See the last paragraph in the Commissioning Instructions for details of the thermal shut-off test and re-adjustment of the maximum temperature setting, if required.

If the maximum water temperature rises by more than 3°C from the commissioned setting then ensure that the strainers are clean and that the isolating valves are fully open. Test the check valves as described below. If these tests do not highlight the reason for the temperature rise then follow the procedure below for investigating failure of the thermal shut-off test.

If the T113/T206 fails the thermal shut-off test then remove the temperature control knob and the thermostatic cover (see installation instructions for details) and check the internal surfaces for scaling.

If the T113/T206 valve body requires descaling then it should be removed from the casing to do this. All rubber  
Issue 5, May 2016

parts must be removed prior to descaling. Do not forget the slide valve seal located inside the valve body, which should always be replaced with a new seal after removal. Maintenance kits are available, which contain “O” rings and/or the thermostat element. Smear all “O” rings with silicon grease/oil prior to installing them. Torque the TSV1-3 cover to 13 Nm (10 lbf). This is to prevent the user from inadvertently unscrewing the cover during temperature adjustment. **Do not** over-tighten the cover.

Replace the “O” rings every three years (maintenance kit with spare “O” rings available). Smear silicone grease/oil on all “O” rings prior to installation. Lightly smear the outside diameter of the slide valve with silicon grease/oil prior to installation.

Replace the thermostatic element and slide valve assembly at least once every 6 years in all TSV1 valves, or more often if problems are experienced or in installations where the water is aggressive.

The on/off mechanism uses a maintenance-free timed flow control cartridge. This cartridge can be changed if necessary.

The check valves prevent cross-flow between hot and cold water supplies under unequal pressure conditions and are designed for long life with no maintenance. Their function can be tested as follows:

To test the check valve on the hot side, shut off the hot supply and ensure that the cold supply is open. Be prepared for leakage of trapped water from the pipe and remove the strainer basket on the hot side.

Any continuing leakage evident from the strainer body is likely to be coming through the hot supply check valve (N.B. Ensure that the hot isolating valve shuts off tightly).

To test the check valve on the cold side, shut off the cold supply and ensure the hot supply is open. Be prepared for leakage of trapped water from the pipe and remove the strainer basket on the cold side.

Any continuing leakage evident from the strainer body is likely to be coming through the cold supply check valve (N.B. Ensure that the cold isolating valve shuts off tightly).

If either check valve is leaking then the inlet elbow (complete with check valve and strainer basket) must be replaced. It is not possible to satisfactorily remove the check valve itself from the inlet elbow and this should not be attempted. The shower valve body must be removed from the pre-plumbed enclosure in order to remove the inlet elbows (see Fig. 10 for the location of the parts).

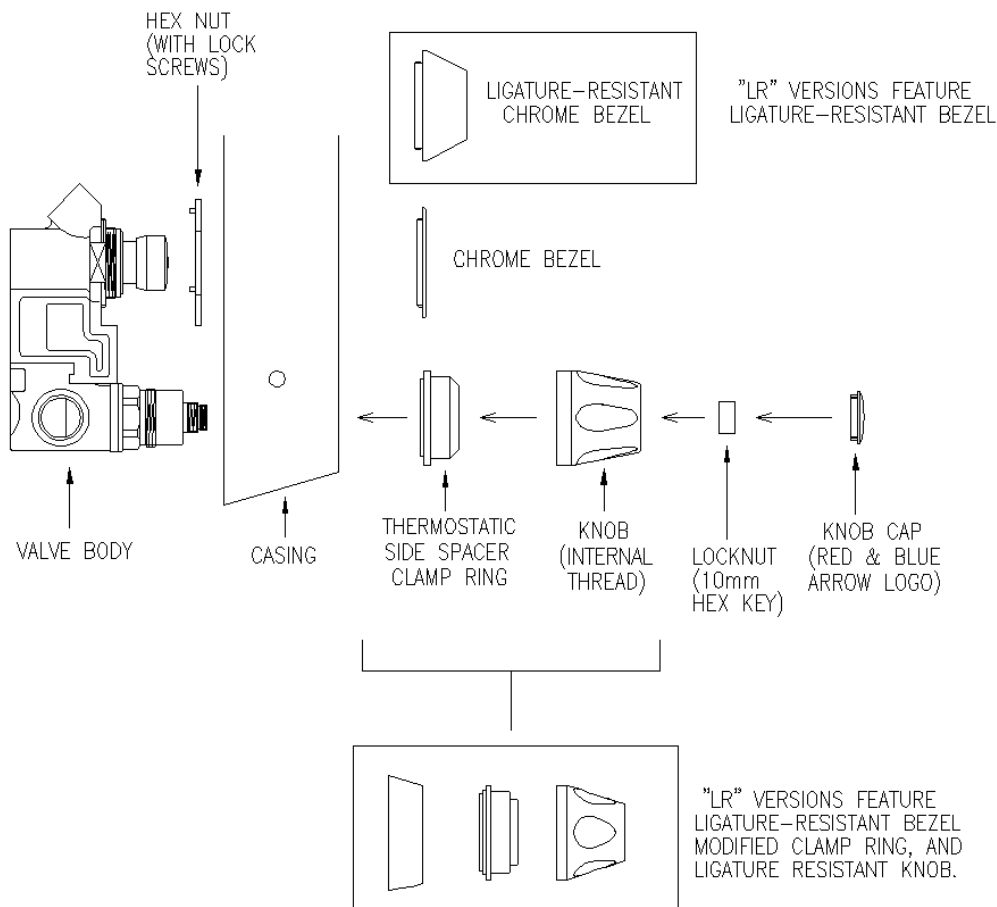

Fig. 10.



TO REMOVE FLOW REGULATOR

- 1> REMOVE THE 2 CAPHEAD SCREWS (USING 3MM HEX KEY)
- 2> PRISE SPRAYPLATE OUT WITH A BLADE OR SIMILAR
- 3> REMOVE THE 2 RETAINING RINGS
- 4> REMOVE FLOW REGULATOR WITH ITS O-RING

STEPS <2> THROUGH <4> CAN BE DONE BY TURNING ON THE WATER SUPPLY AND CATCHING THE PARTS IN A BUCKET

TO RE-FIT FLOW REGULATOR

- 1> INSERT FLOWREG INTO HOLE, FLANGED SIDE UP
- 2> PUSH O-RING INTO GAP AROUND FLOWREG
- 3> INSERT RETAINING RINGS SO THAT THE GAPS ARE FACING OPPOSITE DIRECTIONS
- 4> FIT THE LARGE O-RING ONTO THE SPRAYPLATE AND FIT THE SPRAYPLATE
- 5> RE-FIT THE CAPHEAD SCREWS

NOTE THAT THE SPRAY PLATE CAN BE FITTED IN 2 DIFFERENT ORIENTATIONS TO ALLOW GREATER OR LESSER 'THROW' OF THE WATER.

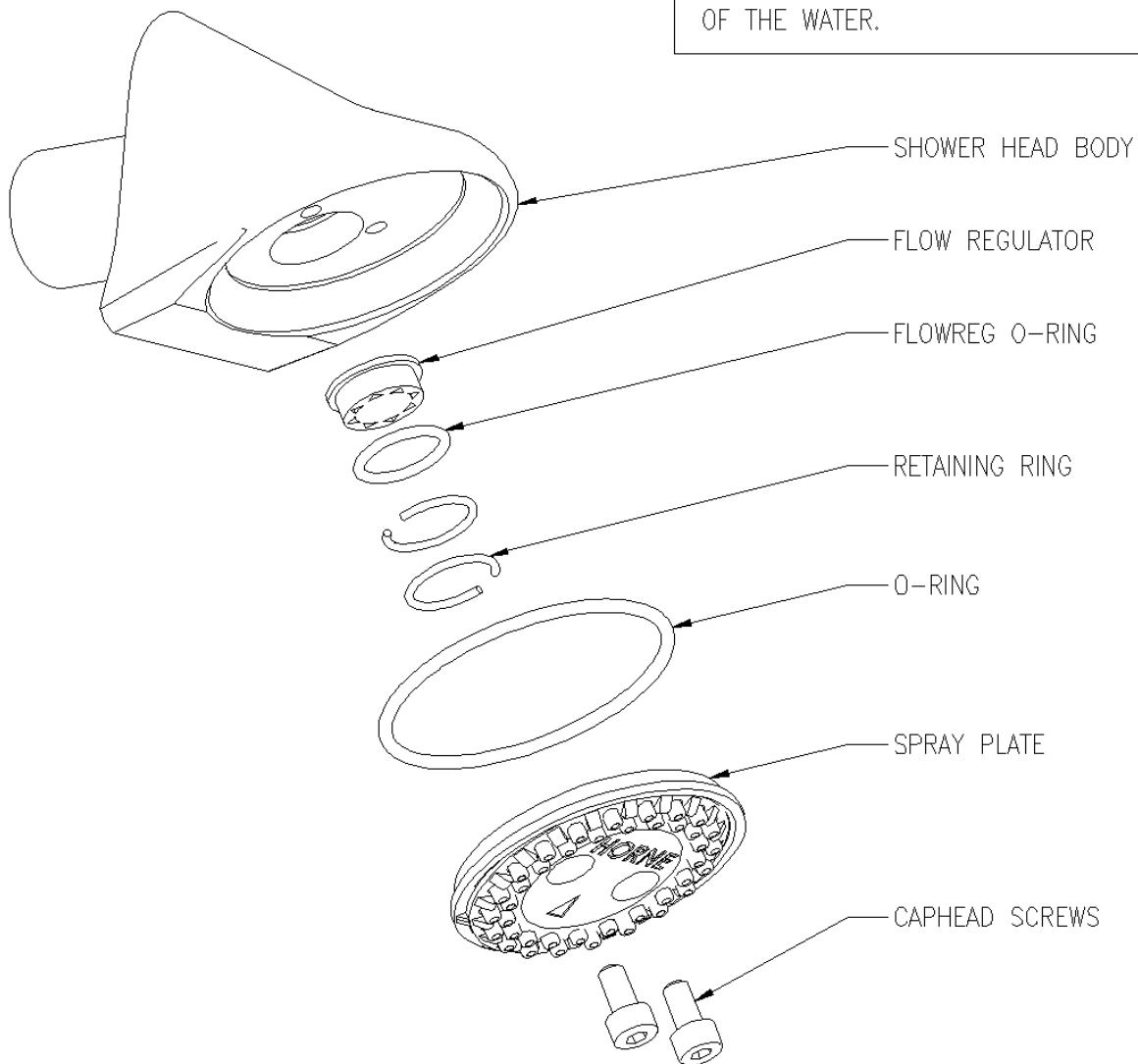

COPYRIGHT 2012, HORNE ENGINEERING LTD. ALL REPRODUCTION PROHIBITED UNLESS AUTHORISED IN WRITING

PART : REMOVAL / REPLACEMENT OF FLOW REGULATOR (VANDAL RESISTANT HEAD)		MATERIAL : MATERIAL SPECIFICATION		HORNE ENGINEERING LTD. JOHNSTONE RENFREWSHIRE	
		PRODUCT : HORNE SHOWER PANELS	SCALE DO NOT SCALE		
		CHECKED		DR'G. No. 10393	
		ISSUE	1		

TO REMOVE/REPLACE FLOW REGULATOR

1. UNSCREW SHOWER HEAD FROM ANGLED TUBE
2. REMOVE RUBBER WASHER
3. REMOVE/REPLACE FLOW REGULATOR (IN CORRECT ORIENTATION IF REPLACING)
4. REPLACE RUBBER WASHER ON TOP OF FLOW REGULATOR
5. SCREW SHOWER HEAD BACK ON

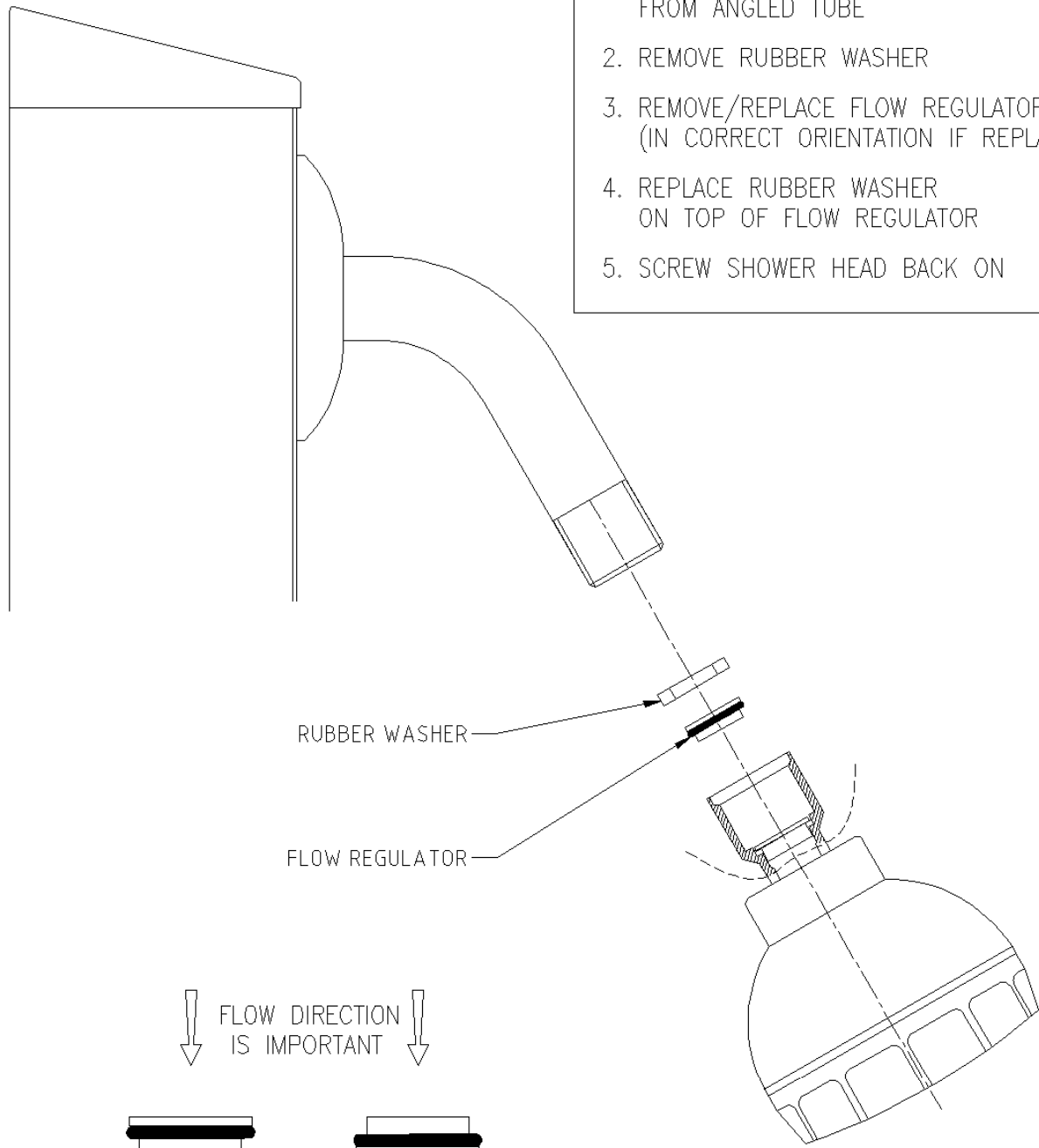

↓ FLOW DIRECTION IS IMPORTANT ↓

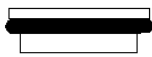

RIGHT

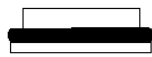

WRONG

COPYRIGHT 2003, HORNE ENGINEERING LTD. ALL REPRODUCTION PROHIBITED UNLESS AUTHORISED IN WRITING

MATERIAL : N/A

HORNE ENGINEERING LTD.  
JOHNSTONE  
RENFREWSHIRE

PART :  
REMOVAL/REPLACEMENT OF  
FLOW REGULATOR

PRODUCT :  
TSV1-106A/AB

SCALE	DO NOT SCALE
DRAWN	GDP 7/12/05
CHECKED	
ISSUE	1

DR'G. No. 9301B



