



HORNE SPORTS PANEL (SP-200A) FOR SURFACE MOUNTING INSTALLATION, OPERATING & MAINTENANCE INSTRUCTIONS

Installation requirements and specification

The Horne Sports Panel provides timed flow control with a fixed sprayhead in a convenient wall mounted panel.

Supply Water Pressure requirements

The minimum water pressure required to feed the Horne Sports Panel is a dynamic head of 0.8 bar (8m head). Optimum performance is obtained between 0.8 bar and 5 bar water pressure. Note that dynamic head is measured with the water running.

Supply Water Temperature Requirements

The Horne Sports Panel does not include any form of temperature control and so it must be supplied with water at a suitable showering temperature with appropriate scald protection (e.g. from a Horne Thermostatic Mixing Valve set to 41°C).

Flow Control

The Horne Sports Panel includes a push-button timed flow control, which allows water to pass for approx. 30 seconds after the control is pressed. It also contains a single check valve and a flow regulator to restrict the water flow rate to approx. 8 l/min at higher pressures.

General

The blended water inlet connection is by ½" BSP male thread flat-faced coupling.

Horne Engineering Ltd
HORNE SPORTS PANEL (SP-200A)
Installation Instructions

General

The Horne Sports Panel is supplied with a fitting kit containing the necessary fixings to attach it to the wall. If possible, use the screws (5mm – No 10) included with the kit as these are made from stainless steel and will not corrode or cause staining of the shower cubicle.

Installation

Installation of Horne Sports Panel is particularly simple and involves mounting the enclosure on the wall and connecting the water supply.

1) *Remove the Bottom Cover of the Horne Sports Panel*

Using a cross head screwdriver, remove the bottom cover of the Horne Sports Panel to reveal the lower Mounting Holes, as shown in Fig 1.

2) *Position the Sports Panel*

Identify a suitable position for the Horne Sports Panel and mark a point on the wall which is approx. 5mm below the required location of the sprayhead. This will be the location of the Top Mounting Hole, See Fig 2. Typically, this is usually around 2.1m up from the shower tray.

3) *Drill the Top Mounting Hole*

Drill a 7.0mm dia hole (or to suit wall fixing being used) in the wall and insert the wallplug.

4) *Temporarily Hang Sports Panel*

Temporarily hang the Horne Sports Panel from the top mounting screw. Do not tighten this screw to clamp the panel to the wall – the panel will hang true from a loose screw. Ensuring that the Horne Sports Panel is hanging true, mark out the location of the lower two mounting screws as shown in Fig 1.

5) *Drill the Lower Mounting Holes*

Remove the Horne Sports Panel from the wall to prevent damage. Drill the two lower mounting screw holes as marked out and put appropriate wall fixings in them.

6) *Flush out the Pipework.*

It is **essential**, to avoid contamination of the timed flow control, that the supply pipework is thoroughly flushed out to remove all debris and contamination **before** connection to the Horne Sports Panel.

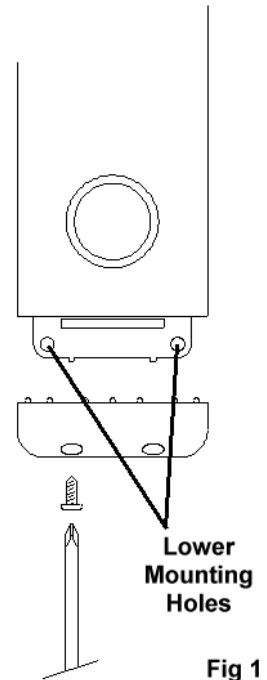

Fig 1

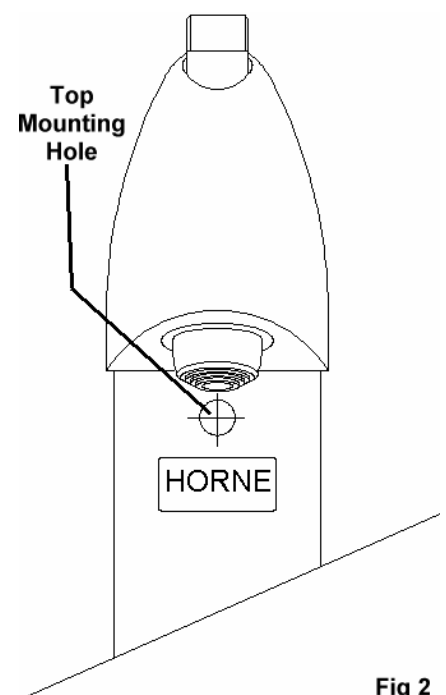

Fig 2

7) *Attach the Horne Sports Panel to the Wall*

Carefully attach the Horne Sports Panel to the wall by the 3 screws provided (or other suitable fixings) and ensure that the supplied washers are also used. Do not overtighten the screws. Note that if alternative fixings are used, stainless steel ones are preferable, or galvanised ones may be used if stainless steel ones are not available. Do not use mild steel or zinc plated fixings – they may rust and stain the shower cubicle. Use the cap provided to cover the top mounting hole.

8) *Replace the Bottom Cover.*

Replace the bottom cover of the Horne Sports Panel using the two screws removed earlier, See Fig 3.

9) *Attach the Blended Water Supply*

Attach the blended water supply to the Horne Sports Panel. The connection is by ½" BSP male thread flat faced coupling at the top of the panel. Remember to fit the supplied strainer in the joint.

Note that the Sports Panel does not contain any form of temperature control mechanism and must be fed with blended water at a suitable shower temperature and with suitable scald protection (e.g. from a Horne Thermostatic Mixing Valve).

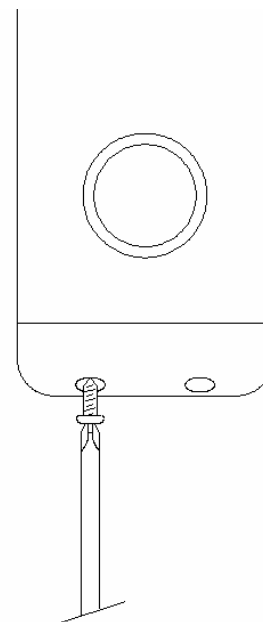

Fig 3

10) *Test for Leaks in Pipework*

Open the water supply to the Sports Panel. Water may initially flow from the sprayhead for a few seconds. After this has ceased check the inlet connection for leaks and clean up the Sports Panel.

DO NOT USE ANY ABRASIVE CLEANERS OR SOLVENTS OR THE SURFACES MAY BE DAMAGED.

11) *Test the Horne Sports Panel*

Press, and hold, the timed flow control button for a few seconds. Water should start to flow from the sprayhead and continue for approx. 30 seconds.

Note that the timed flow control push-button must be held for a few seconds to obtain maximum shower duration. The push-button may be pressed at any time during its sequence to add another 30 seconds to the shower duration. The duration of the shower may be less than 30 seconds if the water supply pressure is below 0.8 bar. During operation of the push-button, a small quantity of water is released by the mechanism behind the pushbutton. This is perfectly normal and is not a fault.

Horne Engineering Ltd
MAINTENANCE

Note that maintenance of the thermostatic mixing valve supplying the shower panel is essential in order to ensure the continued safety of those using the Horne Sports Panel.

The Sports Panel itself has no particular maintenance requirement. If the spray pattern is affected by scaling of the nozzles then they can be removed from the panel for descaling by removing the hex socket screw retaining the spray plates, as shown in Fig 4.

The timed flow control unit is a cartridge which can be removed from the Sports Panel without the need to remove the Sports Panel from the wall, see Fig 5.

To change the Timed Flow Control Cartridge, isolate the water supply to the Sports Panel. Remove the chromed sprayplate retaining housing by gripping it across the two flats and unscrewing it.

Remove the Timed Flow Control Cartridge by engaging a tool in the two holes and unscrewing it.

Reverse the above procedure to re-fit a new cartridge.

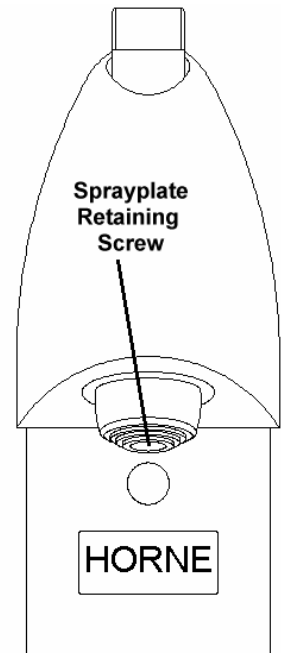

Fig 4

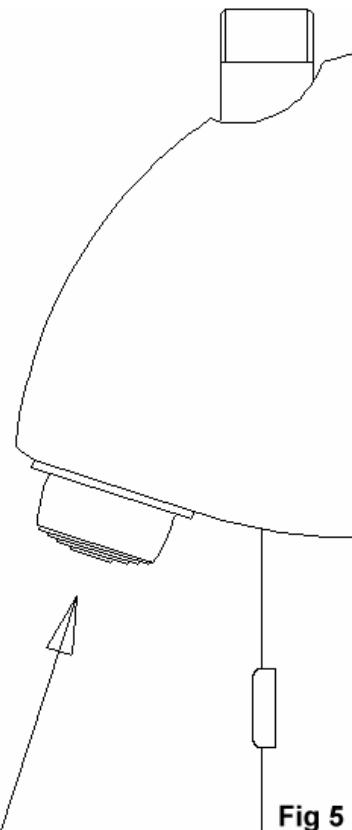
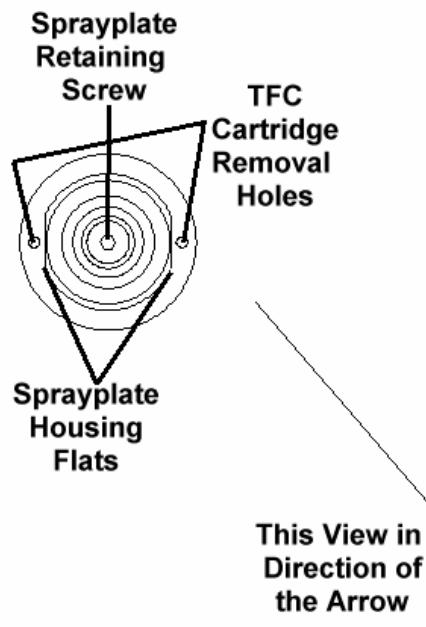

Fig 5



Horne Engineering Ltd
 PO Box 7, Rankine Street
 Johnstone, Renfrewshire
 Scotland. PA5 8BD
 Tel 01505 321 455
 Fax 01505 336 287
 Email technical@horne.co.uk
 Web www.horne.co.uk

In-Line Strainer Installation and Maintenance Instructions

Description

The In-Line Strainer is a cartridge type fine mesh strainer designed to protect the Timed Flow Control mechanism of the SP-200A. The strainer basket is held between flat-faced couplings and can be easily removed for cleaning.

See the drawing on page 3 for details of the parts of the In-Line Strainer.

Installation

The In-Line Strainer should be installed onto the inlet of the SP-200A Sports Panel. The In-Line Strainer has a ½" BSP female thread on the OUTLET CONNECTOR (1) that matches the male thread of the Sports Panel.

Note that a minimum clearance of 100mm must be left between the upper end of the In-Line Strainer and the isolating valve or other nearest item on the pipework.

The upper end of the In-Line Strainer has a compression fitting to connect to 15mm OD copper pipe.

The lower end of the In-Line Strainer has a ½" BSP female thread to enable it to be screwed directly onto the SP-200A Sports Panel. Use thread tape or sealing compound to seal onto the SP-200A thread (**N.B. Ensure that no tape or sealing compound enters the joint as this could cause the Timed Flow Control in the SP-200A to malfunction**)

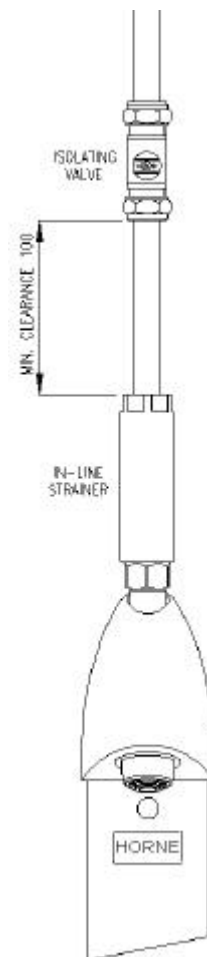

Fig 1

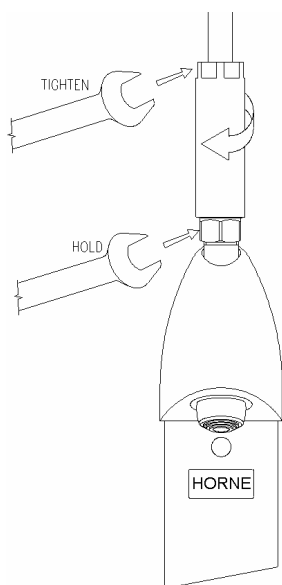

Fig 2

First of all, screw the OUTLET CONNECTOR (1) of the In-Line Strainer onto the SP-200A panel.

Then, with the 15mm copper pipe firmly pushed into place in the compression fitting, use a second spanner to tighten the COVER NUT (3) against the OUTLET CONNECTOR (1), (see Fig 2.)

DO NOT MAKE OFF THE COMPRESSION JOINT BY TIGHTENING THE IN-LINE STRAINER AGAINST THE SP-200A BODY. TIGHTEN THE TWO HALVES OF THE IN-LINE STRAINER AGAINST EACH OTHER.

Turn on the water supply and ensure that there are no leaks.

This completes the installation of the In-Line Strainer.

To Remove the Strainer Basket for cleaning

Using two spanners, slacken the COVER NUT (3) while holding against the OUTLET CONNECTOR (1) and slide the COVER NUT (3) up the pipe (see Fig 3).

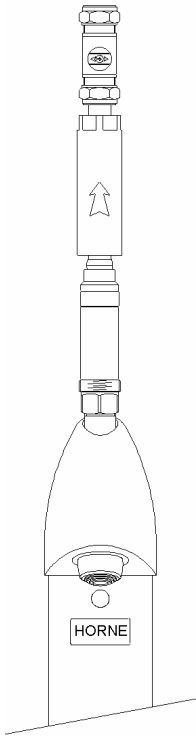

Fig 4

Slide the COVER NUT (3) up to expose the INNER CYLINDER (4) containing the FINE MESH BASKET (10), (see Fig 4).

The INNER CYLINDER (4) is located between two flat faced unions and can be slid out sideways. N.B. The COMPRESSION INLET (7) is loose on the pipe and so should be held in place while the INNER CYLINDER (4) is removed. The COMPRESSION INLET (7) should then be removed and stored carefully while the FINE MESH BASKET (10) is removed for cleaning.

The FINE MESH BASKET (10) is located inside the INNER CYLINDER (4), (see Fig 5.)

Clean the strainer by washing it out under running water. Note that the debris will be trapped inside the FINE MESH BASKET (10) so flush it through from outside to inside.

Replace the FINE MESH BASKET (10) if it cannot be cleaned satisfactorily, or if it becomes damaged during cleaning.

Re-assembly of the In-Line Strainer is a simple matter of reversing the procedure. Do not forget to put the COMPRESSION INLET (7) back in place during re-assembly.

NB. When tightening the COVER NUT (3) ensure that it is tightened against the CONNECTOR (2) and NOT against the SP-200A Sports Panel.

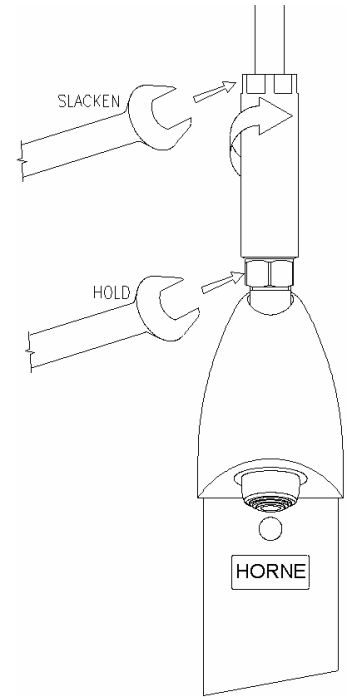

Fig 3

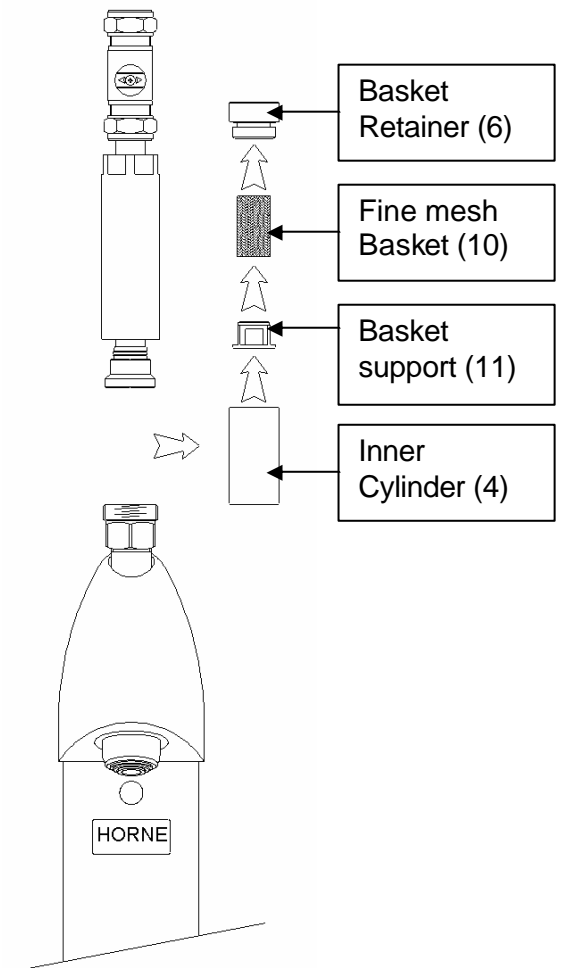
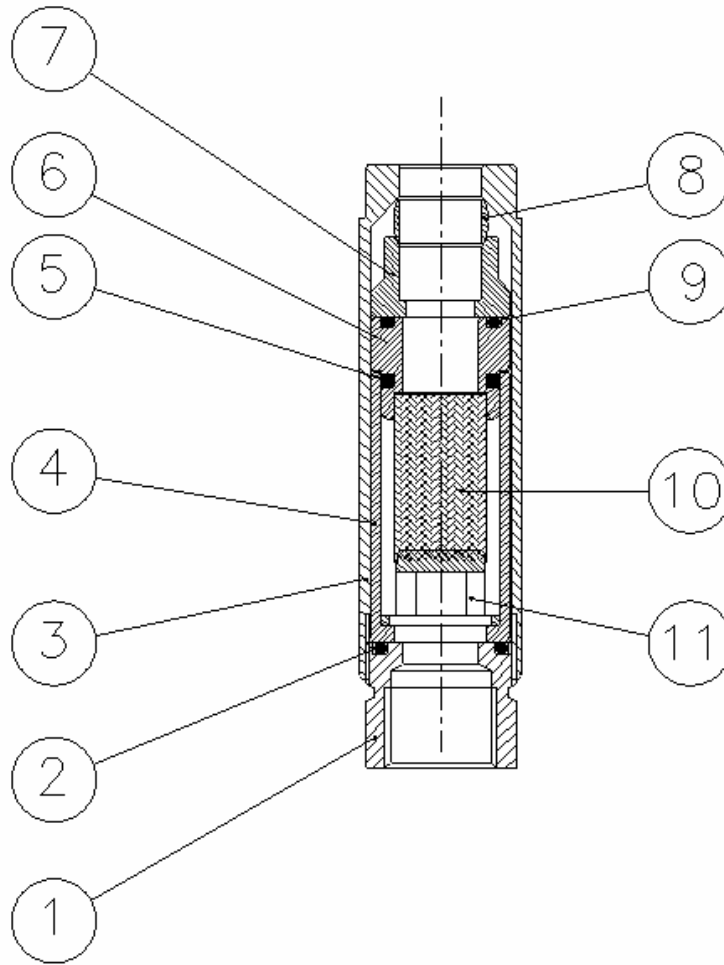

Fig 5



ITEM	DESCRIPTION
1	OUTLET CONNECTOR
2	OUTLET SEAL
3	COVER NUT
4	INNER CYLINDER
5	BASKET RETAINER SEAL
6	BASKET RETAINER
7	COMPRESSION INLET
8	FERRULE
9	INLET FACE SEAL
10	FINE MESH BASKET
11	BASKET SUPPORT

TOLERANCES
(EXCEPT WHERE SPECIFIED)
 ϕ - 50mm \pm 0.3
 ϕ - 100mm \pm 0.3
 ANGLES \pm 1°

PARTS TO BE SUPPLIED
BURR-FREE AND CLEAN

COPYRIGHT 2006, HORNE ENGINEERING LTD. ALL REPRODUCTION PROHIBITED UNLESS AUTHORISED IN WRITING

PROD. 5598

THIS DRAWING CONTAINS CONFIDENTIAL AND PROPRIETARY INFORMATION OF HORNE ENGINEERING LTD AND UNAUTHORISED DISCLOSURE IS STRICTLY PROHIBITED

MATERIAL : -

HORNE ENGINEERING LTD.
JOHNSTONE
RENFREWSHIRE

PART :
ASSEMBLY AND PARTS LIST

PRODUCT :
IN-LINE STRAINER

SCALE	DO NOT SCALE
DRAWN	GDP 22/1/08
CHECKED	
ISSUE	1

DR'G. No. 10317