



HORNE 20 THERMOSTATIC MIXING VALVE

TYPE H-2003

INSTALLATION, COMMISSIONING, OPERATING AND MAINTENANCE INSTRUCTIONS

APPROVAL

The HORNE 20 TMV Type H-2003 has been independently tested by the WRc and approved to all the requirements of *NHS Model Engineering Specifications D 08 Thermostatic Mixing Valves (Health Care Premises)* to the following designations and for the following applications.

APPLICATION	DESIGNATION	HOT AND COLD WATER PRESSURES
BATHS	-HP-T44	1 - 5 bar
	-HP-T46	1 - 5 bar
	-LP-T44	0.2 - 1 bar
SHOWER	-LP-S	0.2 - 1 bar
WASHBASIN	-LP-W	0.2 - 1 bar

The hot and cold pressures do not need to be equal. See 1.3 overleaf.

The HORNE 20 TMV Type H-2003 is a Type 3 Thermostatic Mixing Valve according to NHS Estates Health Guidance Note *"Safe" hot water and surface temperatures*.

1. INSTALLING THE HORNE 20 TMV

- 1.1 Check that the HORNE 20 TMV is approved for the intended application.
- 1.2 Install the HORNE 20 TMV as close as possible to the outlet to comply with HTM 04-01. The dead leg from the HORNE 20 TMV to the outlet should not exceed 2 metres.
- 1.3 If the hot and cold water supplies are of unequal pressures, then the lower of the two pressures should not be less than 0.2 bar maintained pressure.
- 1.4 Isolating valves must be fitted to the hot and cold water supply pipes. The isolating valve on the cold water supply pipe may also be used to isolate the cold water tap.
- 1.5 The HORNE 20 TMV can be fitted in any attitude with the mixed water outlet pointing upwards, downwards, horizontally or any angle between these planes.

2. FLUSHING OF PIPEWORK TO THE WATER SUPPLY (Water Fittings Regulations 1999, schedule 2 G13.1)

The most common cause for complaint regarding the performance of any Thermostatic Mixing Valve is traced to dirt or debris in the TMV or check valves.

Before a HORNE 20 TMV is commissioned, the hot and cold water pipework should be thoroughly flushed using the FLUSHING KIT shown in the diagram below. The FLUSHING KIT comprises a screwed adaptor to fit the strainer body and a plastic pipe to enable water to be flushed to drain. Only one or two kits are required on each site. The kit must be ordered separately.

DO NOT FLUSH THE PIPEWORK BY REMOVING THE STRAINER BASKETS AND OPENING THE TAPS.

DO NOT OPEN the hot water tap before flushing the hot and cold water pipework.

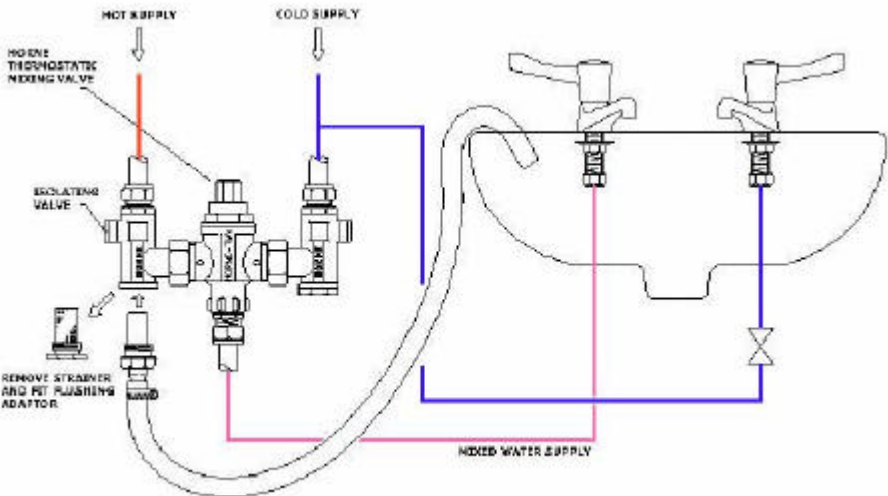

The flushing procedure is as follows:

- 2.01 During this procedure, keep the hot and cold water taps closed.
- 2.02 Close the hot and cold water ISOLATING VALVES.
- 2.03 Unscrew the END CAP (18) and remove the STRAINER BASKET (16) from the strainer at the hot inlet.
- 2.04 Screw the FLUSHING KIT into the STRAINER BODY (15).
- 2.05 Place the outlet of the flushing pipe where it can drain freely. If draining into a wash basin or bath, make sure that the drain plug is NOT in place and that water passing through the flushing pipe is free to drain.
- 2.06 Open hot water ISOLATING VALVE and allow any air in the pipework to escape until water begins to flow to drain. Allow water to flow to drain until it is perfectly clean and free from any dirt or debris.
- 2.07 Close hot water ISOLATING VALVE.
- 2.08 Remove the Flushing Kit and replace the strainer basket and end cap.
- 2.09 Repeat 2.03 to 2.08 at the cold water inlet with cold water ISOLATING VALVE.
- 2.10 Re-open both ISOLATING VALVES.

The flushing procedure has now been completed.

3. COMMISSIONING A NEW HORNE 20 TMV

- 3.1 Open the hot water tap and allow water to run through the HORNE 20 TMV.
- 3.2 Check that hot and cold water supplies are at or near to their designed temperatures and pressures.
- 3.3 Measure the temperature at the hot water tap. This is the temperature of the mixed water.
- 3.4 If necessary, make minor adjustments to the temperature setting as described in Section 4 below.
- 3.5 **CARRY OUT A COLD WATER FAILURE TEST AS BELOW.**
 - 3.5.1 Close the cold water isolating valve and simultaneously measure the mixed water temperature. The flow of mixed water should immediately stop and then a drip or trickle may be seen. The temperature of any water coming from the tap should not be more than 2°C above the mixed water set temperature measured in 3.3 above.
 - 3.5.2 If the HORNE 20 TMV performs satisfactorily, close the hot water tap and open the cold water isolating valve.
 - 3.5.3 If the water coming from the tap is at a temperature of more than 2°C above the mixed water temperature setting, then the HORNE 20 TMV is not cutting off the hot water supply properly. The most likely cause for this to happen is dirt inside the TMV. It should be dismantled and thoroughly cleaned and the pipework flushed again. See 6.3.1 to 6.3.9.
- 3.6 The HORNE 20 TMV is supplied with WFBS listed integral single check valves located in each of the swivel inlet assemblies. To ensure that the check valves are working properly, proceed as follows.
 - 3.6.1 Start with both hot and cold taps closed and both hot and cold isolating valves open.
 - 3.6.2 Close the cold supply isolating valve.
 - 3.6.3 Remove the strainer cap (18) at the cold inlet to the HORNE 20 TMV. After some initial draining of water, there should be no flow whatever. This indicates that the check valve at the cold inlet is giving a tight shut off.
 - 3.6.4 Replace the strainer cap (18) at the cold inlet and open the cold supply isolating valve.
 - 3.6.5 Close the hot supply isolating valve.

- 3.6.6 Remove the strainer cap (18) at the hot inlet. After initial draining of water, there should be no flow of water whatever. This indicates that the check valve at the hot inlet is giving a tight shut off.
- 3.6.7 Replace strainer cap.
- 3.7 The HORNE 20 TMV has now been commissioned.

4. TEMPERATURE ADJUSTMENT

The HORNE 20 TMV is set at the factory to control the mixed water temperature at approximately 42°C.

The range of temperature adjustment is 35 - 46°C.

To alter the temperature setting, carry out the following procedure:

- 4.1 Check that hot and cold water supplies are at or near to their designed temperature and pressure.
- 4.2 Open the mixed water outlet and allow water to flow until the mixed water temperature has stabilised. Make sure that the dead leg from the HWS to the HORNE 20 TMV and from the HORNE 20 TMV to the outlet has fully cleared.
- 4.3 Using the ADJUSTING KEY (1), turn the ADJUSTING SCREW (2) clockwise to reduce the mixed water temperature or anti-clockwise to increase it. Adjustments of not more than half a turn at a time should be made. The temperature at the outlet should be measured and allowed to stabilise before any further adjustments are made.
- 4.4 After making an adjustment, close the hot water supply isolating valve for ten seconds then re-open it and measure the mixed water temperature again. If a further adjustment is required, repeat the procedure.

5. IN-SERVICE TESTING

- 5.1 Periodic testing should be carried out to check whether any deterioration has occurred in the performance of the HORNE 20 TMV.
- 5.2 A COLD WATER FAILURE TEST should be carried out as described in 3.5.1 above. If the water coming from the tap is at a temperature of more than 2°C above the mixed water temperature setting then the HORNE 20 TMV is due for maintenance.

NOTE: A Thermostatic Mixing Valve in need of maintenance can be undetectable in normal use and only become apparent when a disruption occurs in the hot or cold water supply pressures or temperatures.

- 5.3 The frequency of in-service testing depends upon the condition of the water passing through the TMV. In-service testing must be carried out more frequently in hard water areas than in soft water areas. As a general guide, in-service testing should be carried out at intervals somewhere between six months and twelve months. In-service testing should be carried out at least every twelve months and, where the water is hard, the interval may be less than six months. Experience of local conditions and the in-service testing record will dictate the frequency of in-service testing.

6. MAINTENANCE

Maintenance of all Thermostatic Mixing Valves is essential. If a TMV does not operate properly, there is a risk of someone being scalded.

The frequency of maintenance depends upon the condition of the water passing through the TMV. The remarks in 5.3 regarding in-service testing apply equally to maintenance.

'O' Ring Seals should be replaced at least every three years.

The Thermostat Element (6) should be replaced at least every six years.

All other parts should be replaced only if physical damage has occurred.

MAINTENANCE PROCEDURES

6.1 Close hot and cold water inlet isolating valves and open the outlet to allow pipework to drain.

6.2 **CLEANING STRAINERS** - Unscrew END CAPS (18) and withdraw STRAINER BASKETS (16). Clean the baskets and de-scale them, if necessary.

6.3 **THERMOSTATIC MIXING VALVE MECHANISM**

Minor maintenance carried out with the HORNE 20 in situ.

6.3.1 Unscrew VALVE COVER (3). Remove THERMOSTAT ELEMENT (6), SLIDE VALVE ASSEMBLY (7), RETURN SPRING (8) AND BAFFLE TUBE (9).

6.3.2 The SLIDE VALVE ASSEMBLY (7) is a precision part and must be handled with care.

6.3.3 Remove the ADJUSTING SCREW (2) by turning it clockwise until the thread disengages.

- 6.3.4 The SLIDE VALVE SEAL (10) can be removed by piercing the rubber with a sharp pointed probe. Take care not to bruise the edges of the groove.
- 6.3.5 If the SLIDE VALVE SEAL (10) has been removed, then it MUST be replaced with a new one. NEVER re-use an 'O' Ring.
- 6.3.6 Thoroughly clean all components.
- 6.3.7 Flush out the valve body by replacing the VALVE COVER (3) and ADJUSTING SCREW (2) and opening the isolating valves and allowing water at full bore to pass through the body to the outlet.
- 6.3.8 If dirt is seen during flushing then carry out FLUSHING PROCEDURE in Section 2.
- 6.3.9 Re-assemble the HORNE 20 TMV. (See 6.5)
- 6.4 Major Maintenance. For this, remove the HORNE 20 TMV from the pipework.
 - 6.4.1 Unscrew PIPE COUPLING NUTS (13) and the OUTLET PIPE COUPLING.
 - 6.4.2 Lift the valve out of the pipework.
 - 6.4.3 DO NOT grip the valve body in a vice. This could distort the body and jam the internal parts.
 - 6.4.4 Remove the valve cover and internal parts as referred to in 6.3.1 to 6.3.4 above.
 - 6.4.5 If the valve body requires de-scaling, remove all O-Ring seals and use a proprietary fluid for this purpose. Do not put the THERMOSTAT ELEMENT (6) or the BAFFLE TUBE (9) in de-scaling fluid.
 - 6.4.6 Inspect the condition of the "HOT VALVE FACE" and "COLD VALVE FACE". If the valve faces show signs of deterioration, they can be resurfaced as follows.
 - 6.4.7 Using a mandrel (Tool No. 6356), lap the hot valve face using a water soluble scouring paste. Use 800 Grade wet abrasive paper on a flat surface to lap the "COLD VALVE FACE".
 - 6.4.8 Reassemble the HORNE 20 TMV.

6.5 RE-ASSEMBLY

6.5.1 When fitting new O-Rings, it is advisable to smear them sparingly with a WRAS listed silicone grease.

6.5.2 Insert the components into the HORNE 20 TMV in the order shown on Drawing 6355.

NOTE: The flanged end of the BAFFLE TUBE (9) must be inserted first into the valve body.

6.5.3 Insert the ADJUSTING SCREW (2) into the VALVE COVER (3) and turn anti-clockwise until the top of the Adjusting Screw is approximately 5mm below the top of the Lockshield.

6.5.4 When the internal components have been located loosely in the valve body, place the VALVE COVER (3) over the ELEMENT ASSEMBLY (6) then push gently and turn until the thread on the Valve Cover engages with the valve body. The internal components are self-aligning.

6.6 CHECK VALVES

Check valves are located within the STRAINER BODY (15). They are not removable. They are designed for a long, maintenance free life.

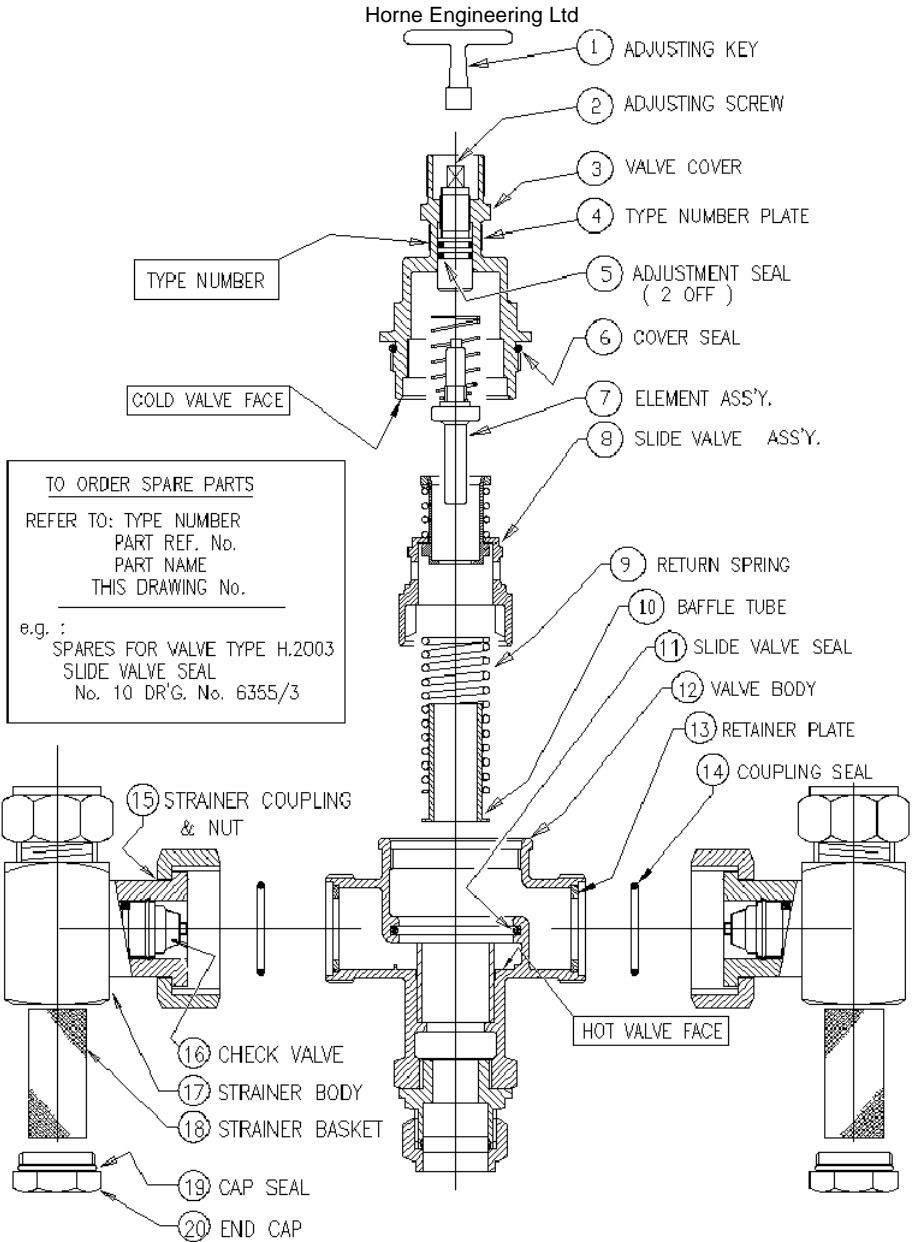

THE HORNE-20 THERMOSTATIC MIXING VALVE TYPE: H2003

DR'G.No. 6355/3

FAULT FINDING CHART

SYMPTOM	POSSIBLE CAUSE	ACTION	REFER TO SECTION
Mixed water temperature too high	Temperature setting too high. Temperature has been set when the hot water temperature is too low	Re-adjust temperature setting	4
	Hot water has migrated into cold water supply	Inspect Check Valve at cold inlet If the check valve leaks replace the strainer body and check valve sub-assembly	3.6.1 to 3.6.6 See Drg.6355
	Thermostat Element has failed. This can be checked by carrying out a hot or cold water failure test.	Replace element (6)	6
Mixed water temperature too low	Temperature Setting too low	Re-adjust temperature setting	4
	Hot water supply temperature has fallen	Check hot water supply system	3.2
	Cold water has migrated into hot supply	Inspect Check Valve at hot inlet If the check valve leaks replace the strainer body and check valve sub- assembly.	3.6.1 to 3.6.6 See Drg 6355
	Cold valve face requires cleaning	Remove valve Cover (3) and service valve face	6.4.7
Mixed water flow rate too low.	Partly blocked strainers	Clean strainers	6.2
	Unusually high pressure drop in supply pipework	Check all valves are full open. Check Pressurisation unit Check mains supply	
	Extra Demand added to system	Check pipe sizing	
Mixed water temp does not respond to adjusting screw	Slide-Valve (7) is seized	Valve requires de-scaling	6.4.5
	Hot and cold inlets reversed	Remove HORNE 20 TMV from pipes and reverse connections. Connect inlet with red dot to hot pipe	
Mixed water temp changes and is not steady	Slide-Valve (7) is seized	Valve requires De-Scaling	6.4.5
	Thermostat element has failed (This can be checked by carrying out a hot or cold water failure test)	Replace element (6)	6
Water at outlet runs full hot or full cold	Hot and cold inlets are reversed	Hot inlet is marked with Red dot Cold inlet is marked with Blue dot	
Valve continues to pass cold water when hot supply is isolated	Cold valve face requires cleaning	Remove valve cover (3) and service cold valve face	6.4.7
	Fouling at hot valve seat	Clean hot valve face	6.4.7
Valve continues to pass hot water when cold supply is isolated	Slide-Valve seal is damaged	Replace Slide-Valve Seal (10)	6.3.4 & 6.3.5
	Element has failed	Replace Element (6)	6